



<http://support.kesseboehmer.de/eboxx>

Montageanleitung

eBoxx - SW
LED-Set

Mounting Instructions

eBoxx - SW
LED-Set

Notice de montage

eBoxx - SW
LED-Set

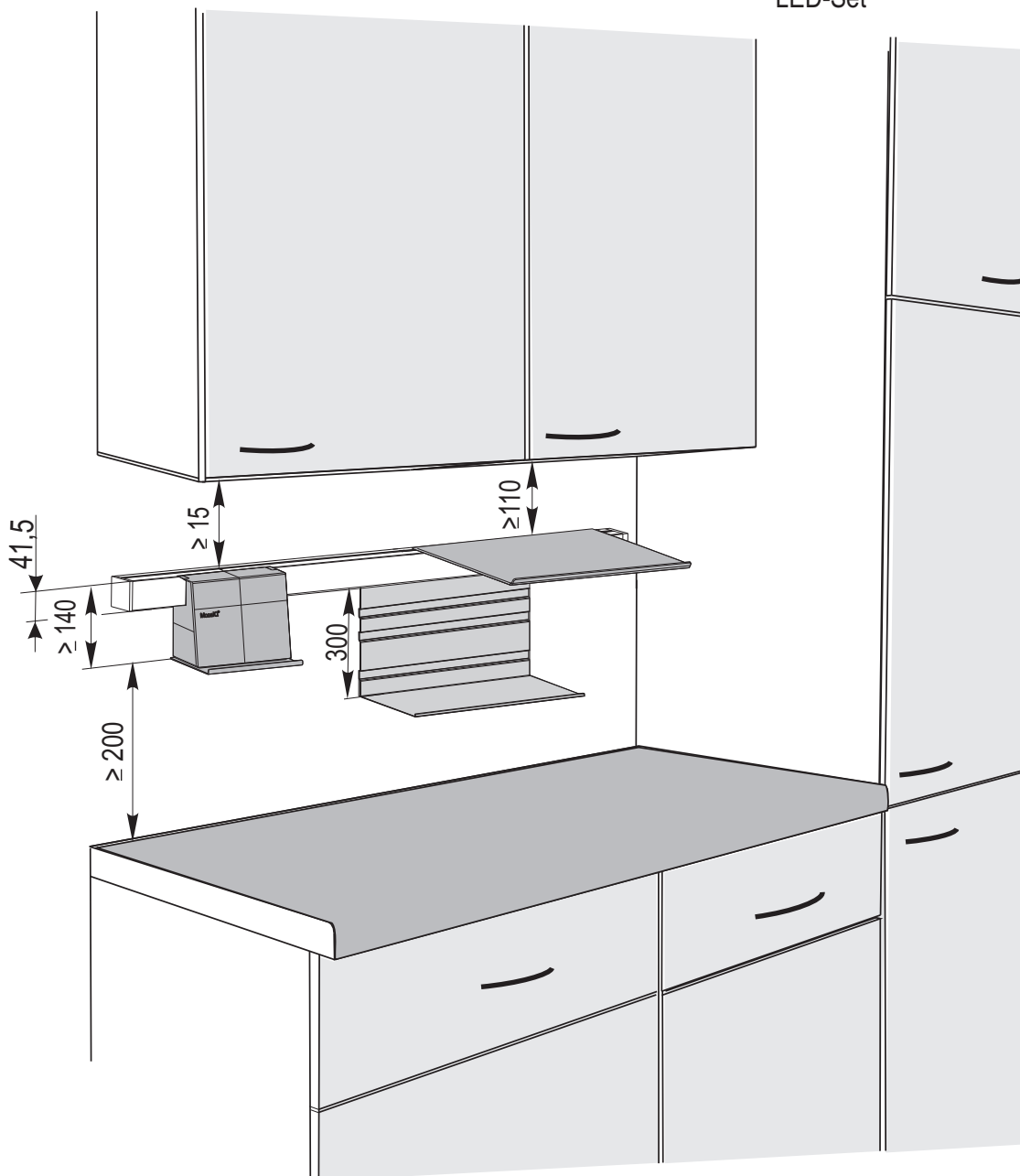



SYMBOLE • SYMBOLS • SYMBOLES • SYMBOLI • SIMBOLOS • SIMBOLOS • MERKIT • SYMBOLER • SYMBOLY • SYMBOLE •



Warnung! • Warning! • Avertissement! • Avvertenza! • ¡Advertencia! • Aviso! • Varoitus! • Advarsel! • Výstraha! • Ostrzezenie! •



Nicht korrekt! • Incorrect! • Incorrect! • Non corretto! • ¡Incorrecto! • Incorrecto! • Väärin! • Ikke korrekt! • Nesprávně! • Nieprawidłowo!



Korrekt! • Correct! • Correct! • corretto! • ¡Correcto! • Correcto! • Oikein! • Korrekt! • Správně! • Prawidłowo!!



Fixieren/fixiert! • Secure/Secured! • Fixer/fixé • Fissare/fissato! • ¡Fijar/fijado! • Fixar/fixo! • Kiinnitä/kiinnitetty! • Spænde/sændt •



Lösen/gelöst! • Release/Released! • Détacher/détaché • Allentare/allentato! • ¡Soltar/suelto! • Soltar/solto! • Irroita/irroitettu! • Løsne/løsnet • Povolit/povolento! • Zwolnic/zwolnione!



Keinen Akkuschauber verwenden! • Do not use a cordless screwdriver! • Ne pas utiliser de tournevis à piles • Non utilizzare un avvitatore a batteria! • ¡No utilizar tladro atornillador! • Não usar aparafusadora sem fio! • Älä käyttää akkuruvinväännintä! • Brug ikke batteriskruetrækker! • Nepouzivejte akušroubovák! • Nie używać wkrtarki akumulatorowej! •



PZ-2 Schraubendreher verwenden! • Use a PZ-2 screwdriver! • Utiliser un tournevis PZ-2 • Usare il cacciavite Pz-2! • ¡Utilizar un destornillador PZ-2! • Usar chave de parafusos PZ-2! • Käytä PZ-2 ruuviataltta! • Brug PZ-2 skruetrækker! • Pouzijte krizový šroubovák PZ-2! • Użyc wkrętaka PZ-2!



Optionales Element! • Optional element! • Élément optionnel! • Elemento opzionale! • ¡Elemento opcional! • Elemento opcional! • Valinnainen elementti! • Valgfrit element! • Voltitelný prvok! • Element opcjonalny! •



Klick-Geräusch beim Einrasten! • Audible click on engagement! • <<Clic>> lors de l'encliquetage • Quando si innesta si sente un clic! • ¡Ciaondo encaja se oye un clic! • Ruído de clique ao engatar! • Lukittuessa kuuluu klik-ääni! • Klikyd ved monterging! • Slyšitelné zacvaknutí! • Trzask przy zaskakiwaniu! •



Alle Maße in mm! • All dimensions in mm! • Toutes les dimensions en mm! • Tutte le dimensioni in mm! • ¡Todas las medidas son en mm! • Todas as medidas em mm! • Kaikki mitat mm! • Alle mal er mm! • Vsechny rozmery v mm! • Wszystkie wymiary w mm! •

Die technische Darstellung und Maßangaben -auch bei Abbildungen und Zeichnungen - sind unverbindlich. Konstruktionsverbesserungen sind vorbehalten! • Technical information and stated dimensions (including in illustrations and drawings) must not be regarded as binding. Design subject to change without notice (in interest of improvement)! • Les illustrations techniques et les cotes y compris sur les schémas et les dessins sont non contractuelles. Sous réserve d'améliorations de la construction! • Le rappresentazioni tecniche e le indicazioni delle dimensioni anche nelle figure e nei disegni non sono vincolanti. Con riserva di miglioramenti di progettazione! • Las descripciones técnicas y los datos dimensionales, inclusive los incluidos en fotos y figuras, son meramente orientativos y no vinculantes. ¡Reservado el derecho a mejoras constructivas! • As descrições técnicas e as indicações de medidas também em ilustrações e desenhos não são de natureza imperativa. Salvo melhoramentos de construção! • Tekniset piirrokset ja mitat myös kuvissa ja piirroksissa olevat ovat sitoumuksetta. Oikeus teknisiin parannuksiin pidätetään! • De tekniske fremstillinger og måleangivelser også i figurer og tegninger er vejledende. Forbehold for konstruktionsforbedringer! • Technické znázornění a rozměry i na obrázcích a výkresech jsou nezávazné. Konstrukční změny vyhrazeny! • Prezentacje techniczne i dane wymiarowe także na rysunkach są niewiązace. Zmiany konstrukcyjne zastrzeżone! •

LINERO MosaiQ



KESSEBÖHMER

i

Input AC 100-240V
50/60 Hz

Output DC 24V
36 Watt *
max 1,5A
EN 61 347

2000 mm

* 5 m LED

max 3500 W

1

mm

145

≥ 25

≥ 25

2

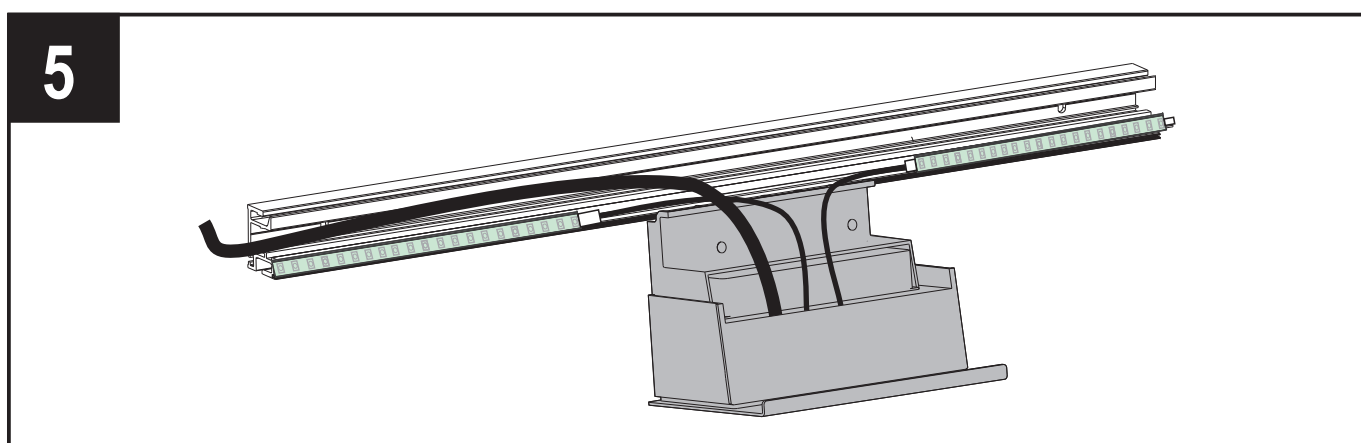
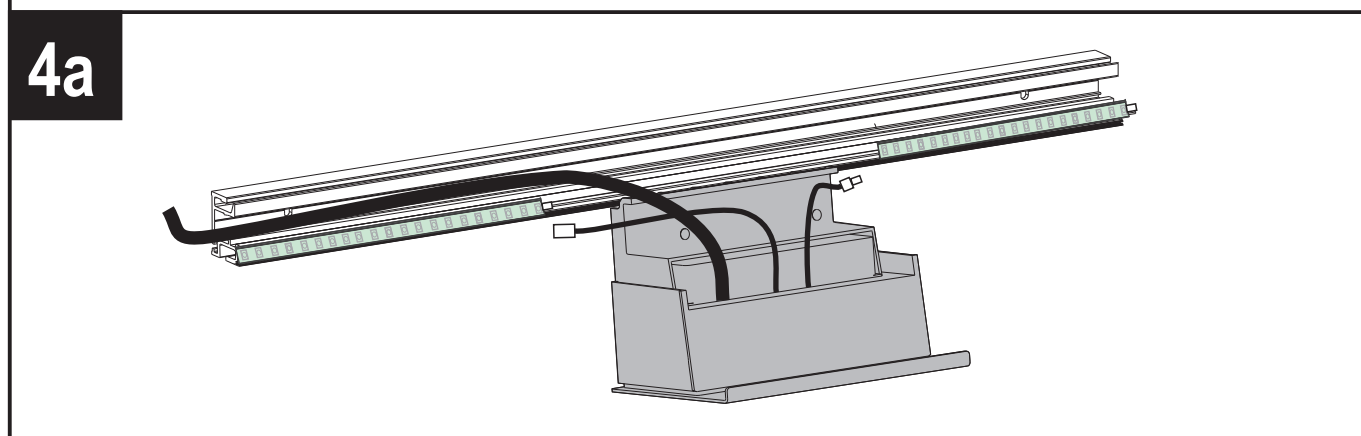
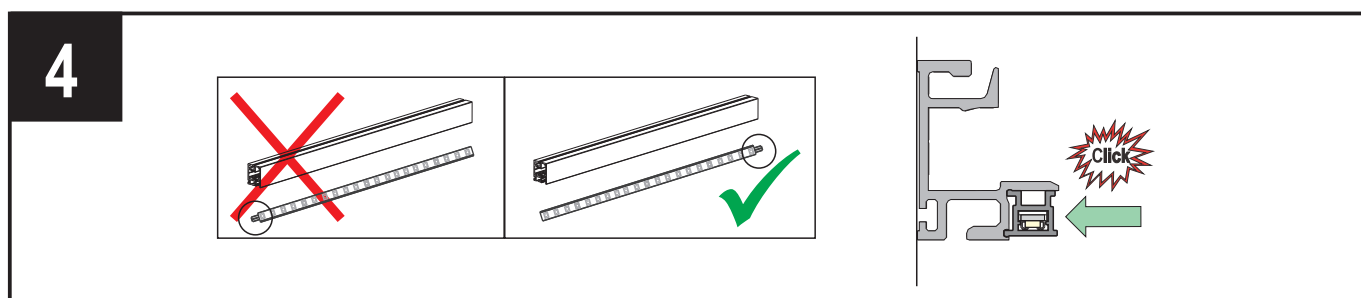
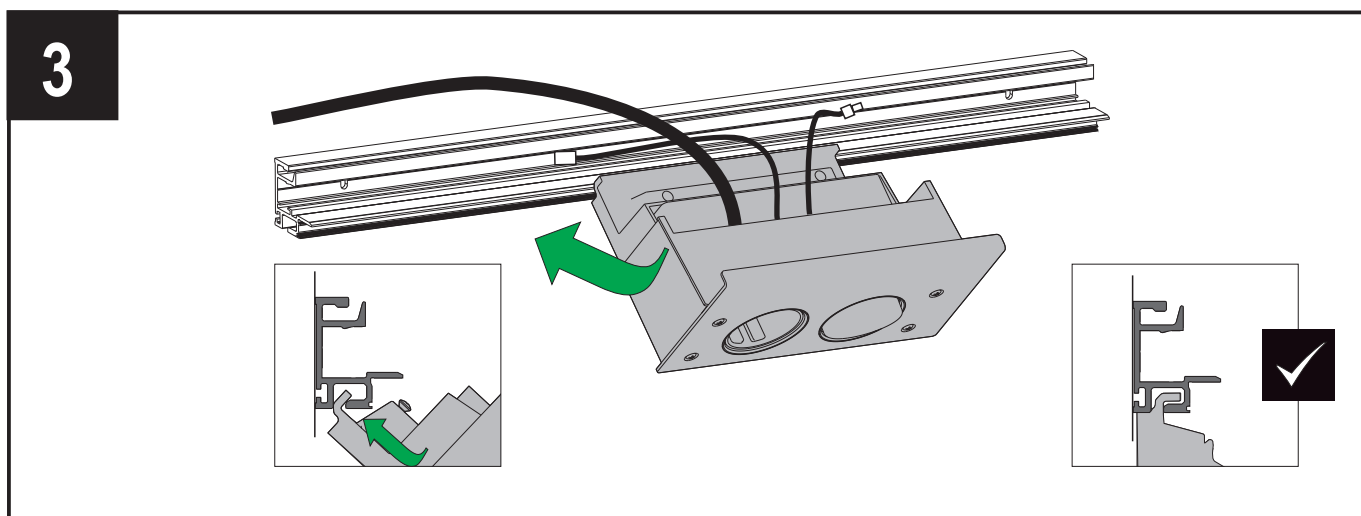

6

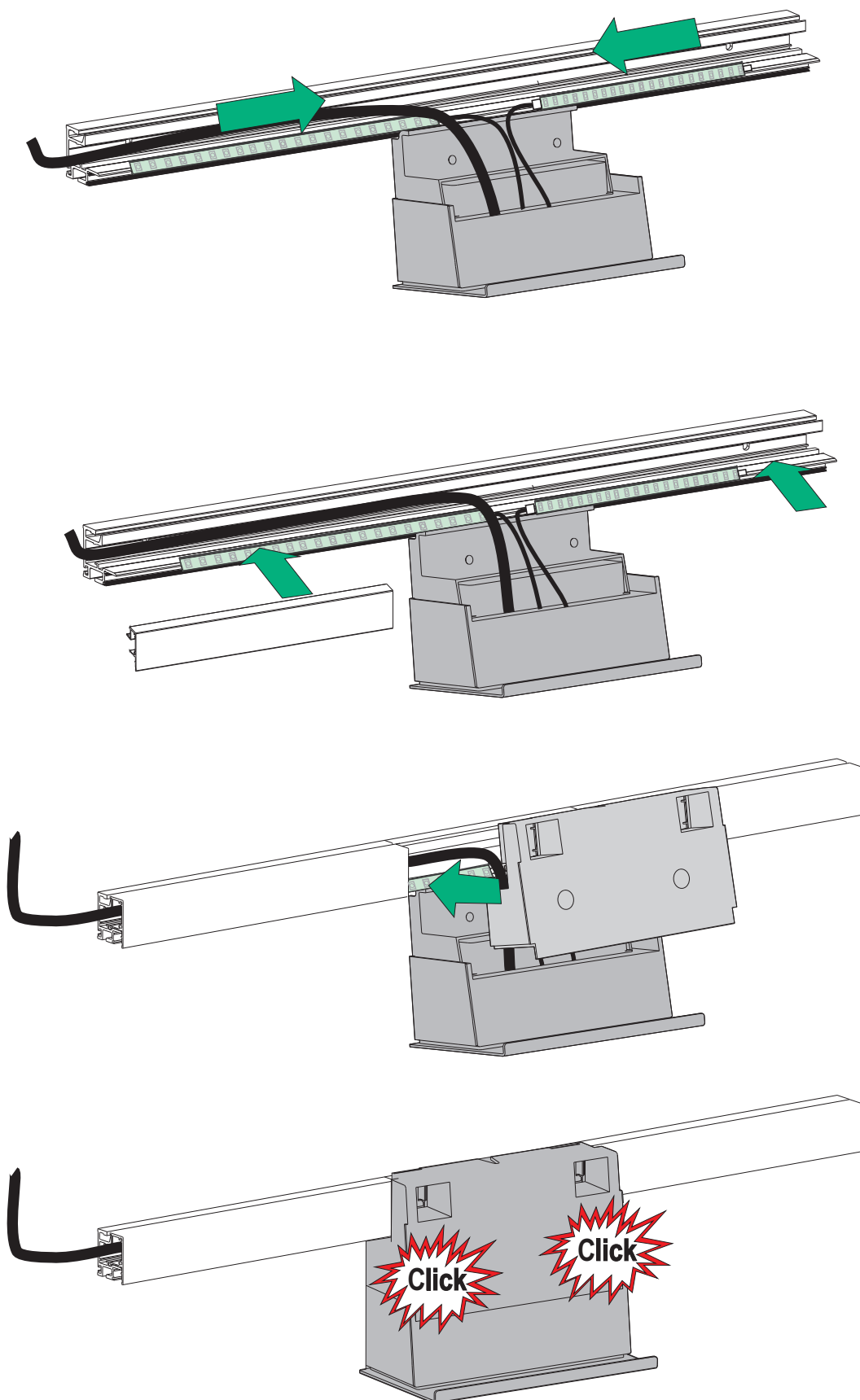

7

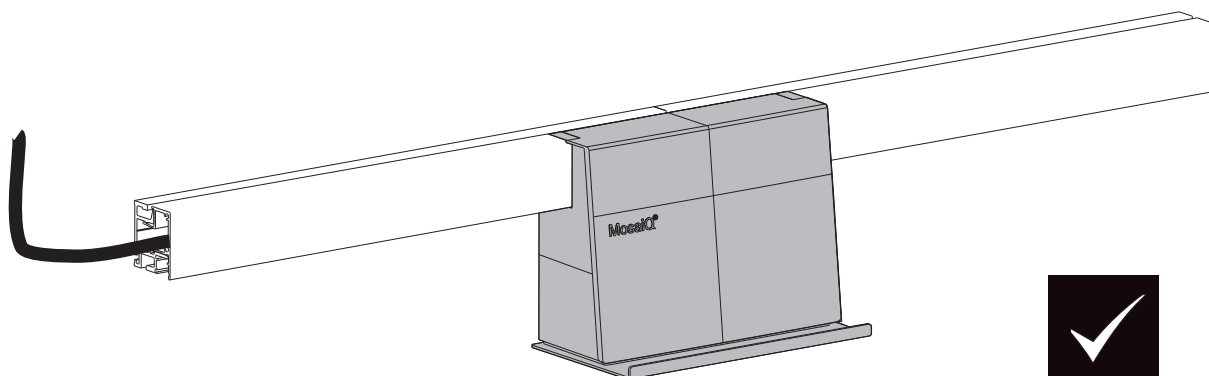
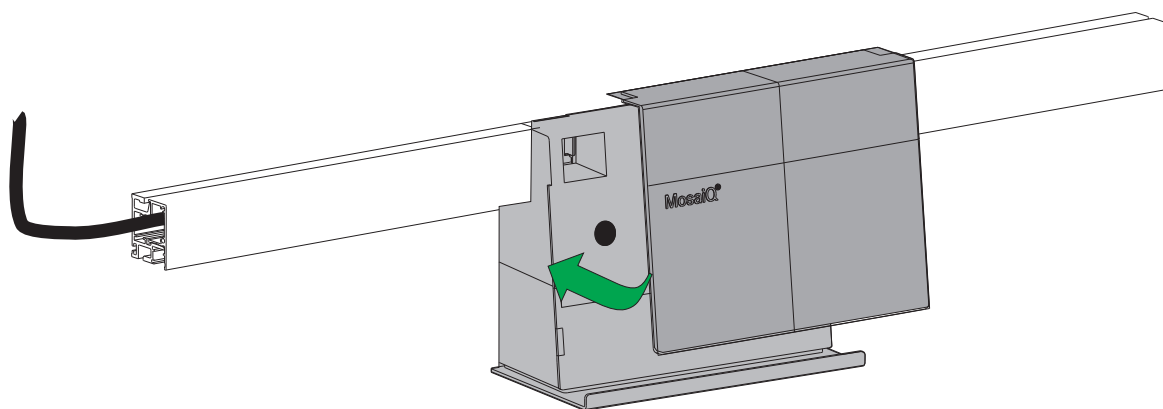
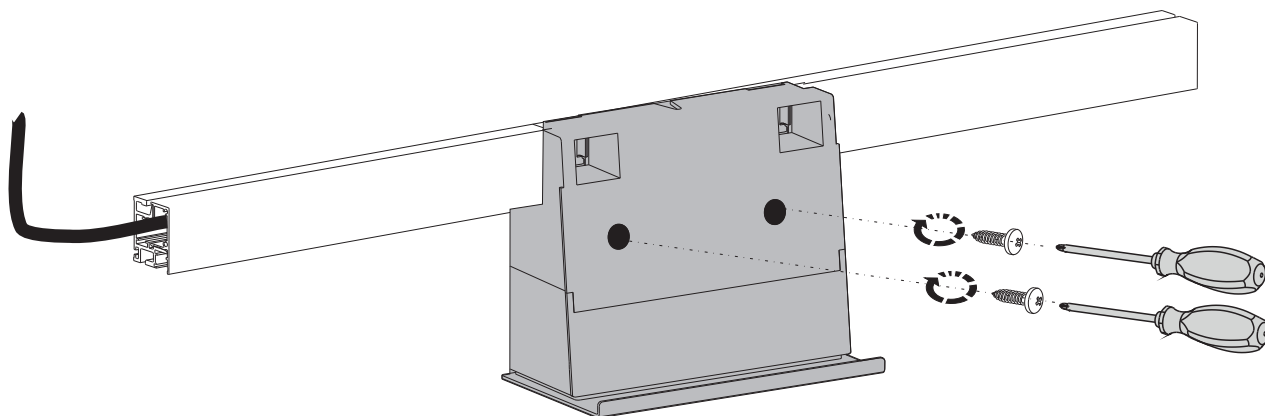

i

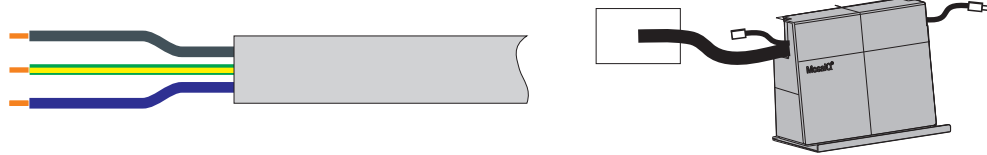

Montage in Wandauslassdose

DE

gelb-grün	○
blau	○
braun	○

Schutzleiter
Neutralleiter
Außenleiter



Achtung

Einbau und Montage elektrischer Geräte dürfen nur durch Elektrofachkraft erfolgen. Um elektrischen Schlag zu vermeiden, schalten Sie die Netzleitung spannungsfrei. (Sicherungsautomat ausschalten)

Elektroninstallationen dürfen nur vom Fachmann unter Berücksichtigung der DIN57100/VDE0100 Teil 701 durchgeführt werden.

Connection in wall outlet socket

UK

Yellow-green	○
Blue	○
Brown	○

Protective earth
Neutral conductor
Outer conductor



Warning

Electrical appliances may only be installed by a qualified electrician. To avoid an electric shock, the mains power supply must be switched off at the fuse box.

Electrical installations may be performed only by qualified persons in accordance with DIN57100/VDE0100 Part 701.

Montage dans la prise murale

FR

jaune-vert	○
bleu	○
marron	○

Tierra
Conducteur neutre
Conducteur extérieur



Attention !

L'installation et le montage d'appareils électriques doivent être impérativement réalisés par un électricien. Pour éviter les risques de choc électrique, déconnectez l'alimentation hors tension (désactiver le coupe-circuit automatique).

Les installations électriques doivent uniquement être effectuées par du personnel spécialisé en respectant la norme DIN57100/VDE0100 partie 701.

Montaggio in presa di uscita a parete

IT

giallo-verde	○
blu	○
marrone	○

Conduttore di protezione
Conduttore neutro
Conduttore esterno



*Attenzione!

Installazione e montaggio di apparecchi elettrici vanno eseguiti solo da personale specializzato. Per evitare scosse elettriche, togliete l'alimentazione di rete (spegnere l'interruttore automatico).

Installazioni elettriche devono essere eseguite solo da persona qualificata in conformità con la DIN57100/VDE0100 parte 701.

Montaje en caja de enchufes de pared

ES

amarillo-verde	○
azul	○
marrón	○

Terre
Conductor neutro
Conductor externo



*Atención!

El montaje e instalación de dispositivos eléctricos debe ser a cargo de electricistas profesionales. Para evitar una descarga eléctrica, interrumpa el suministro eléctrico (desconecte el interruptor general automático)."

La instalación eléctrica debe correr a cargo de un especialista respetando las normas DIN57100/VDE0100 Parte 701.

Montagem em caixa de saída de parede

PT

amarelo-verde	○
azul	○
castanho	○

Condutor de protecção
Condutor neutro
Condutor externo



*Uwaga!

Zabudowej montaż urządzeń elektrycznych może wykonywać wyłącznie wykwalifikowany elektryk. Aby uniknąć porażenia prądem elektrycznym, należy odłączyć przewód sieciowy od zasilania (wyłączyć bezpiecznik automatyczny)."

A execução das instalações eléctricas só é permitida a nível de observação da norma DIN57100/VDE0100 Parte 701.

Pistorasiakytöntä

FI

keltainen-vihreä	○
sininen	○
ruskea	○











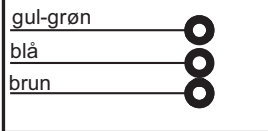

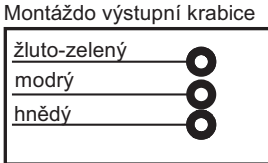

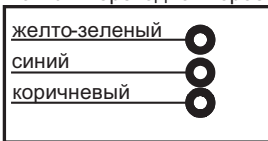

Suojajohdin
Nollajohdin
Ulkojohdin



Huomio!

Sähkölaitteita saa asentaa vain sähköalan ammattilainen. Kytke verkkojohto jännitteettömäksi sähköiskun välttämiseksi (kytke automaattisulake pois päältä).

Sähköasennuksen saa tehdä vain sähköalan ammattihenkilön ohjeiden mukaisesti. Sääntöjen mukaan DIN 57100 / VDE 0100 osan 701 ohjeiden mukaisesti.

i	DK	<p>Montering i vægstikkontakt</p> 	<p>Jordledning Nulleder Ydre leder</p> 	<p>„Giv agt! Indbygning og montering af elektrisk udstyr må kun foretages af autoriserede elektrikere. For at undgå elektrisk stød skal lysnetledningen gøres spærret (sluk for sikringsautomater!).“</p>
	CZ	<p>Montáždo výstupní krabice</p> 	<p>Ochranný vodič Neutrální vodič Vnější vodič</p> 	<p>„Pozor! Vestavba a montáž elektrických přístrojů smí provádět pouze elektrikář. Aby nedošlo k úrazu elektrickým proudem, dříve stovné rozvody do beznapětového stavu (vypněte jistič).“</p>
	PL	<p>Montaż w ściennej puszce połączeniowej</p> 	<p>Przewód ochronny Przewód neutralny Przewód zewnętrzny</p> 	<p>"Atenção! A execução da instalação e da montagem de aparelhos elétricos é permitida a um electricista qualificado. Para evitar um choque eléctrico, separe a linha de rede elétrica (desligar o disjuntor).“</p>
	RU	<p>Монтаж переходной коробки</p> 	<p>Защитный провод Нейтральный проводник Наружное направление</p> 	<p>«Внимание! Установка и монтаж электрического оборудования должны проводиться исключительно специалистами-электриками. Для предотвращения поражения электрическим током обязательно сетевой провод (выключить защитный автомат).“</p>
	TR	<p>Duvar büatma montaj</p> 	<p>Toprak Nötr iletken Dişiletken</p> 	<p>"Dikkat! Elektrikli cihazları takılması ve montajı sadece elektrik uzmanları tarafından yapılmalıdır. Bir elektrik çarpmasını engellemek için şebeke hattını gerilimsiz hale getirin (sigorta otomatik olarak kapanır).“</p>
	GR	<p>Συναρμολόγηση στο κουτί ρίξας τοίχου</p> 	<p>Γείωση ασφαλείας Ουδέτερος αγωγός Εξωτερικός αγωγός</p> 	<p>„Προσοχή! Η τοποθέτηση και συναρμολόγηση ηλεκτρικών συσκευών επιτρέπεται να εκτελείται μόνον από ειδικευμένους ηλεκτρολόγους. Για την αποτροπή ηλεκτροπληξίας θέστε τη γραμμή ρεύματος πίσω (κλείστε την αυτόματη ασφάλεια).“</p>
	JP	<p>壁コンセントへの取り付け</p> 	<p>保護接地線 中性線 外部導体</p> 	<p>「注意！ 電気機器の取り付けと設置は、資格のある電気技師のみが行うことができます。 電気ショックを回避するために、電源供給の電源を切ってください（ブレーカーを落としてください）。」</p>
	CN	<p>墙壁电源插座上安装</p> 	<p>保护导体 中性导体 外导体</p> 	<p>“注意！ 只允许由电气专业人员安装和装配电气设备。 为了避免触电，请切断电源线的电压（关闭断路器）。”</p>