

# Montageanleitung

für Hochschwenkbeschlag im Oberschrank  
mit 1 oder 2 Gasdruckfedern  
Art.-Nr. 231100.0102

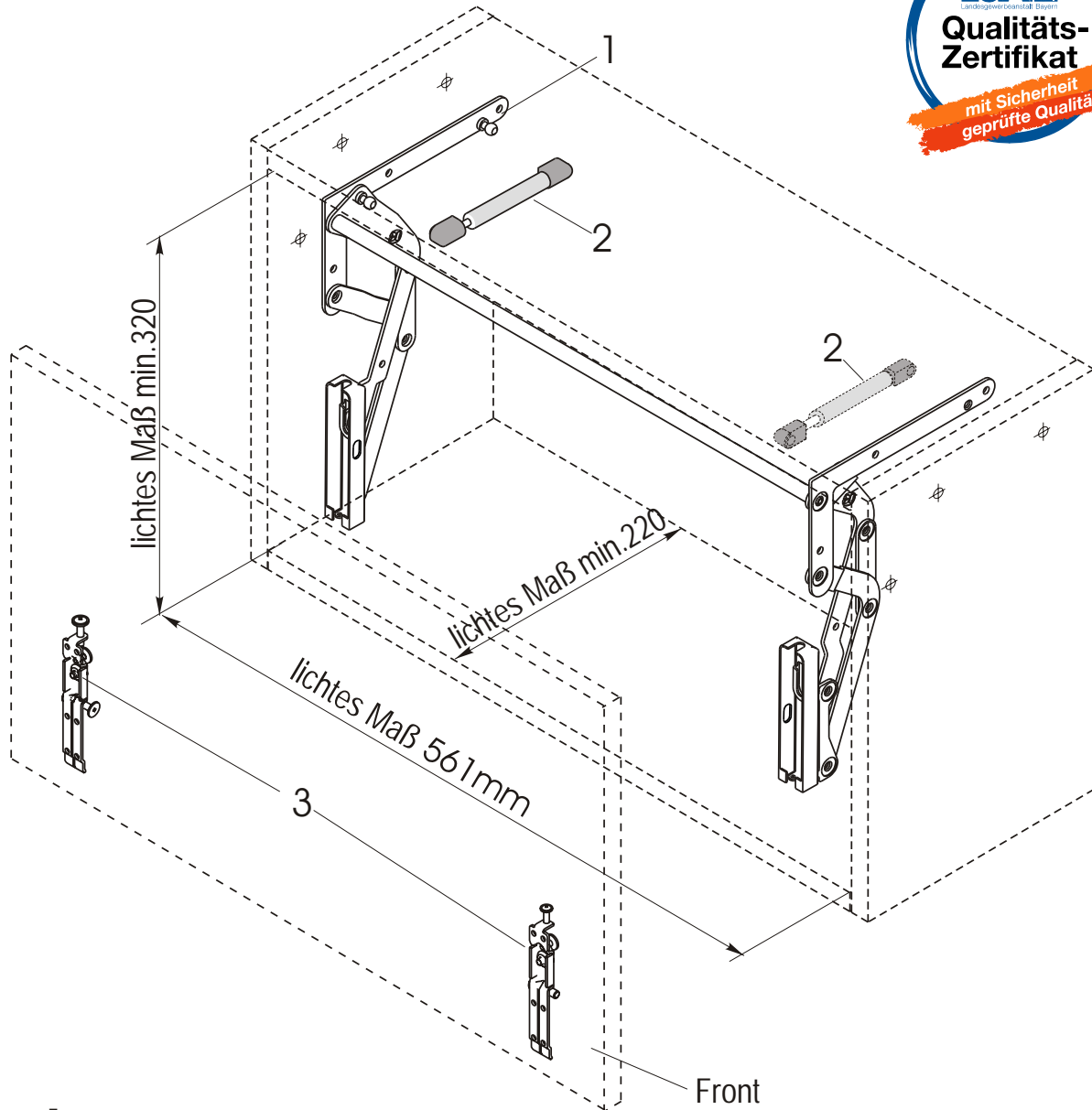

1. Hochschwenkbeschlag

2. Gasfeder

3. Montageplatten

**A.** Hochschwenkbeschlag einschrauben

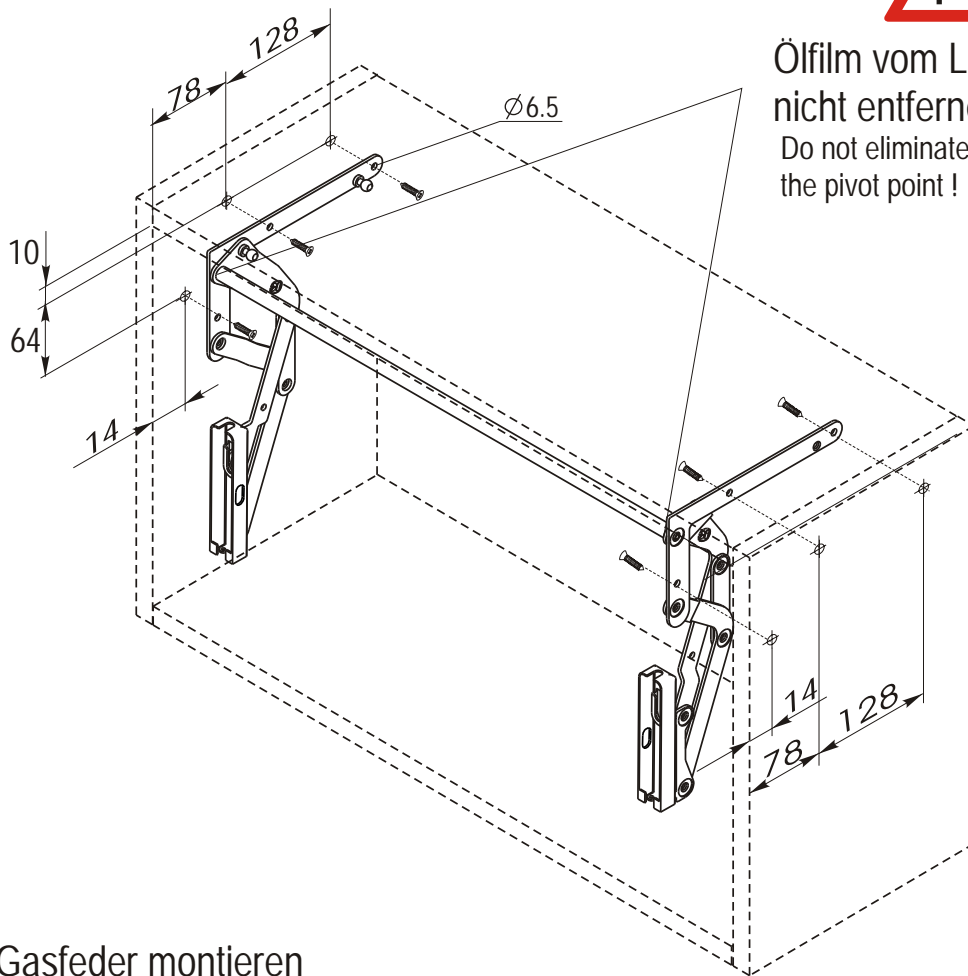

**B.** Gasfeder montieren

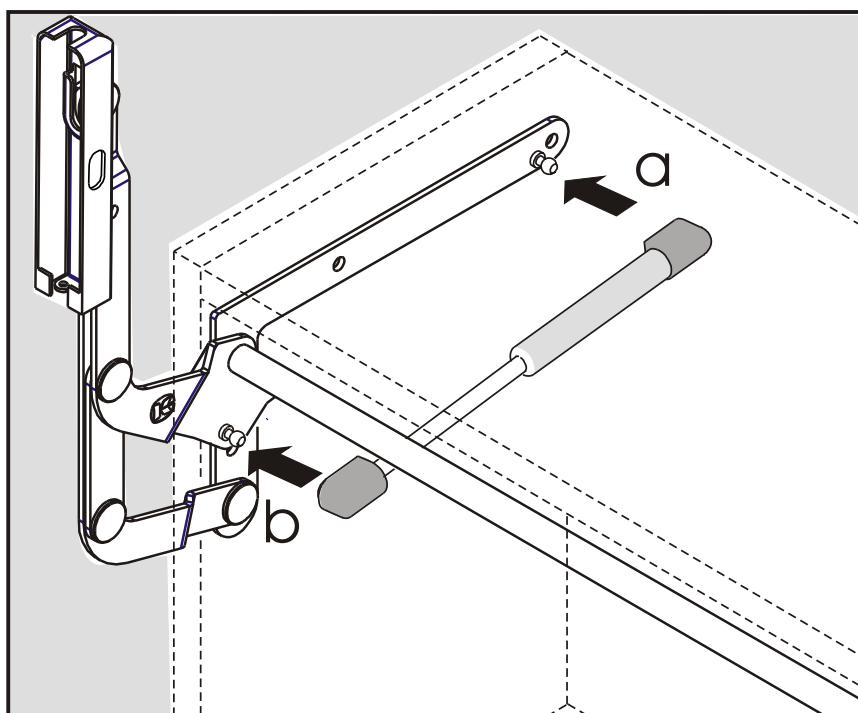

**C.** Montageplatten an der Front verschrauben

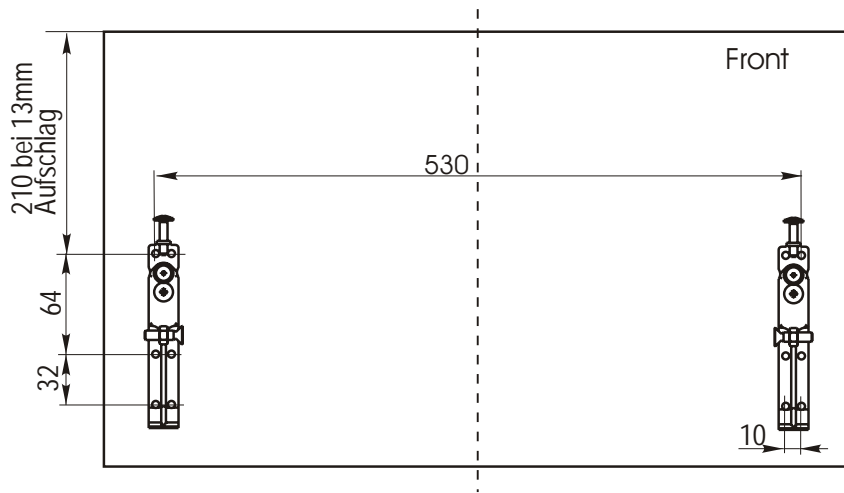

**D.** Front einhängen und montieren  
Front justieren

